

# NTC Thermistor for Automotive: TSM-C Series



## SMD NTC Thermistor for Temperature Sensing

### ■ Features

1. Qualification based on AEC-Q200 Rev-C
2. Operating temperature range: -50 ~ +150 °C
3. Superior stability in high-temperature and high-humidity environment
4. RoHS & Halogen Free (HF) compliant



### ■ Recommended Applications

1. Car audio, car navigation
2. Various engine control units
3. Circuits for ETC equipment
4. Various motor driving circuits
5. Temperature compensation for various circuits

### ■ Part Number Code

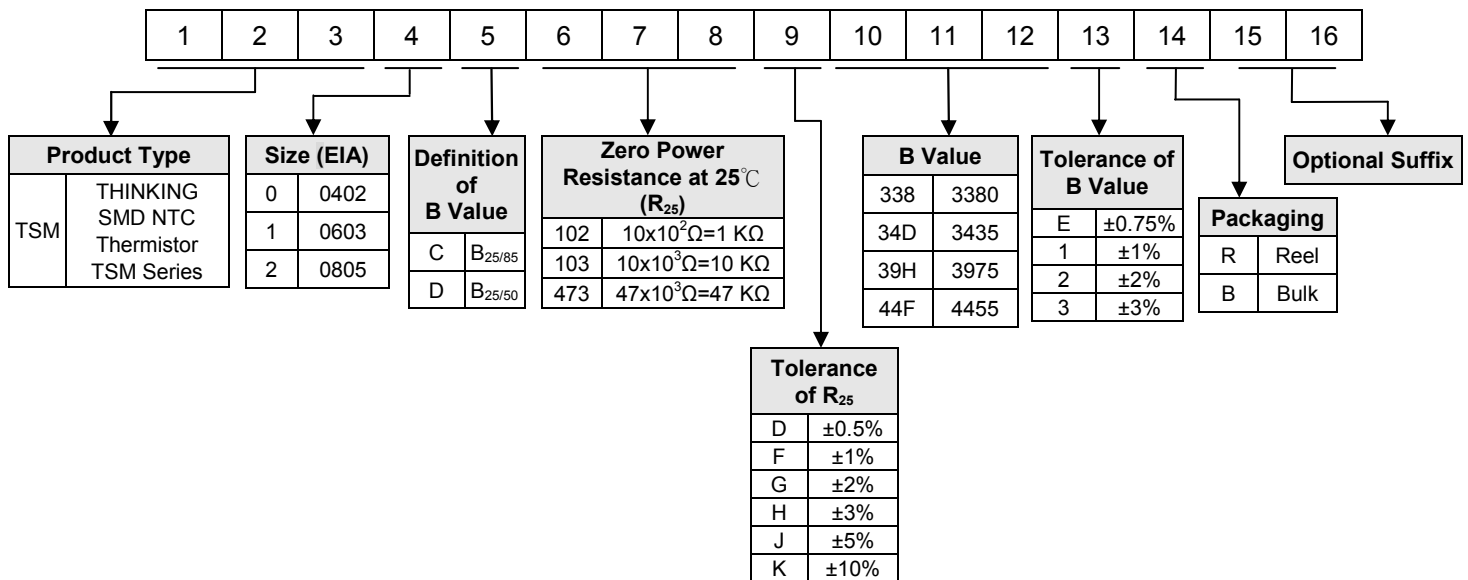

### ■ Structure and Dimensions

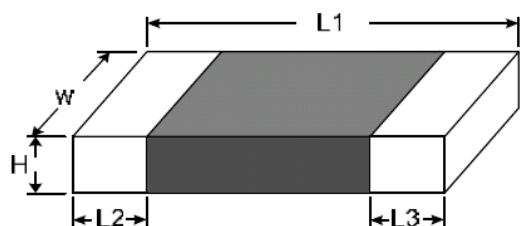

(Unit: mm)

Part No.	Size(EIA)	L1.	W	H max.	L2 & L3
TSM0	0402	1.00±0.15	0.50±0.10	0.60	0.20±0.10
TSM1	0603	1.60±0.15	0.80±0.15	0.95	0.40±0.15
TSM2	0805	2.00±0.20	1.25±0.20	1.00	0.40±0.20

### Electrical Characteristics

Part No.	Size	Zero Power Resistance at 25°C	Tolerance of R <sub>25</sub>	B Value		Tolerance of B value	Max. Power Dissipation at 25°C	Dissipation Factor	Thermal Time Constant	Operating Temperature Range					
		R <sub>25</sub> (KΩ)	(±%)	(K)		(±%)	P <sub>max</sub> (mW)	δ(mW/°C)	τ(Sec.)	T <sub>L</sub> ~T <sub>U</sub> (°C)					
TSM0C103□34D*	0402	10	0.5,1,2,3,5,10	25/85	3435	0.75,1,2,3	170	Approx. 1.7	Approx. 2.0	-50 ~ +150					
TSM0D103□338*		10		25/50	3380										
TSM0D104□425*		100	1,2,3,5,10	25/50	4250	1,2,3									
TSM1C472□385*	0603	4.7	1,2,3,5,10	25/85	3850	1,2,3	210	Approx. 2.1	Approx. 3.1	-50 ~ +150					
TSM1C682□395*		6.8		25/85	3950										
TSM1C103□34D*		10	0.5,1,2,3,5,10	25/85	3435	0.75,1,2,3									
TSM1D103□338*		10		25/50	3380										
TSM1C103□395*		10	1,2,3,5,10	25/85	3950	1,2,3									
TSM1C473□39H*		47			3975										
TSM1C104□425*		100		4250											
TSM1D103□390*		10		3900											
TSM1D473□405*		47		25/50	4050										
TSM1D104□455*		100			4550										
TSM2C472□347*		0805	4.7	1,2,3,5,10	25/85	3470					1,2,3	240	Approx. 2.4	Approx. 5.4	-50 ~ +150
TSM2C103□34D			10			3435									
TSM2C103□395*	10		3950												
TSM2C473□39H*	47		3975												
TSM2C104□429*	100		4290												
TSM2D223□395*	22		25/50		3950										

Note 1: □ = Tolerance of R<sub>25</sub> (D: ± 0.5%, F: ± 1%, G: ± 2%, H: ± 3%, J: ± 5%, K: ± 10%)

Note2: \* = Tolerance of B value (E: ± 0.75%, 1: ± 1%, 2: ± 2%, 3: ± 3%)

Note3: R<sub>25</sub> and B are available upon request

### Max. Power Dissipation Derating Curve

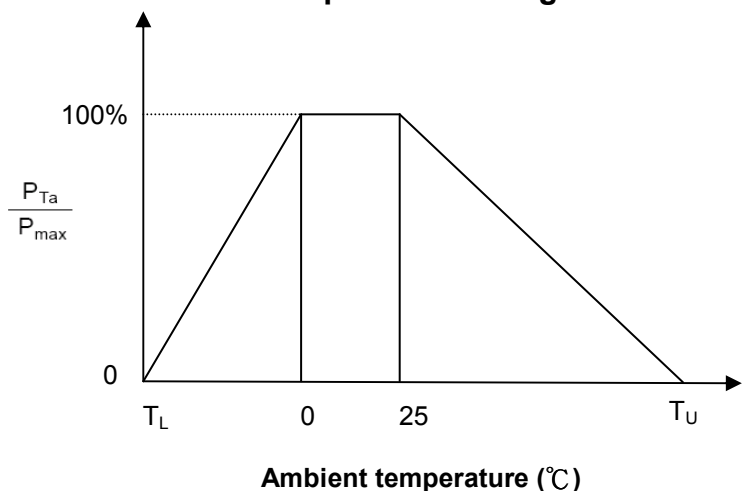

T<sub>U</sub> : Maximum operating temperature (°C)

T<sub>L</sub> : Minimum operating temperature (°C)

For example :

Ambient temperature (T<sub>a</sub>)=55°C

Maximum operating temperature (T<sub>U</sub>)= 150°C

$P_{Ta} = (T_U - T_a) / (T_U - 25) \times P_{max} = 76\% P_{max}$



### ■ R-T Characteristic Curves

#### 0402 Series

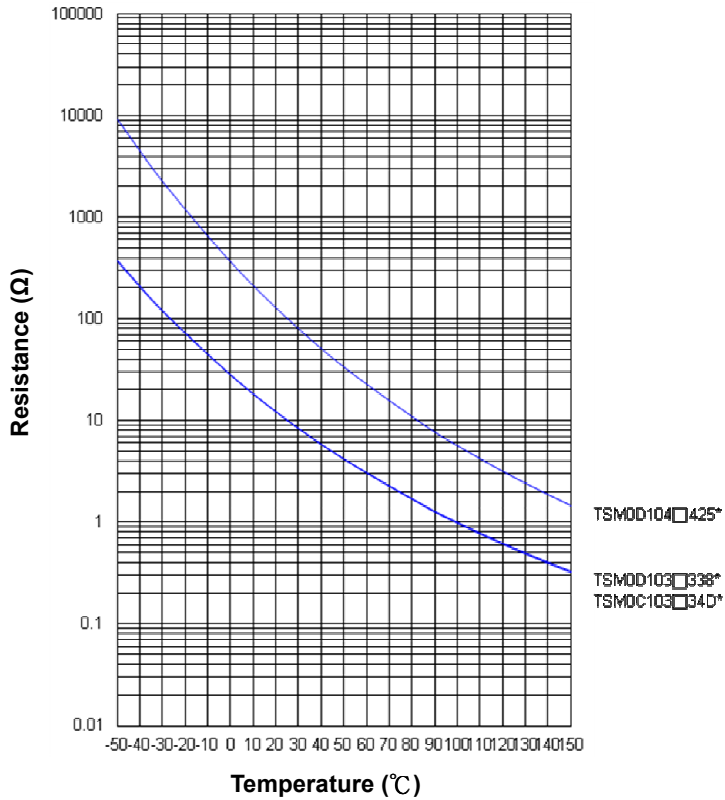

#### 0603 Series

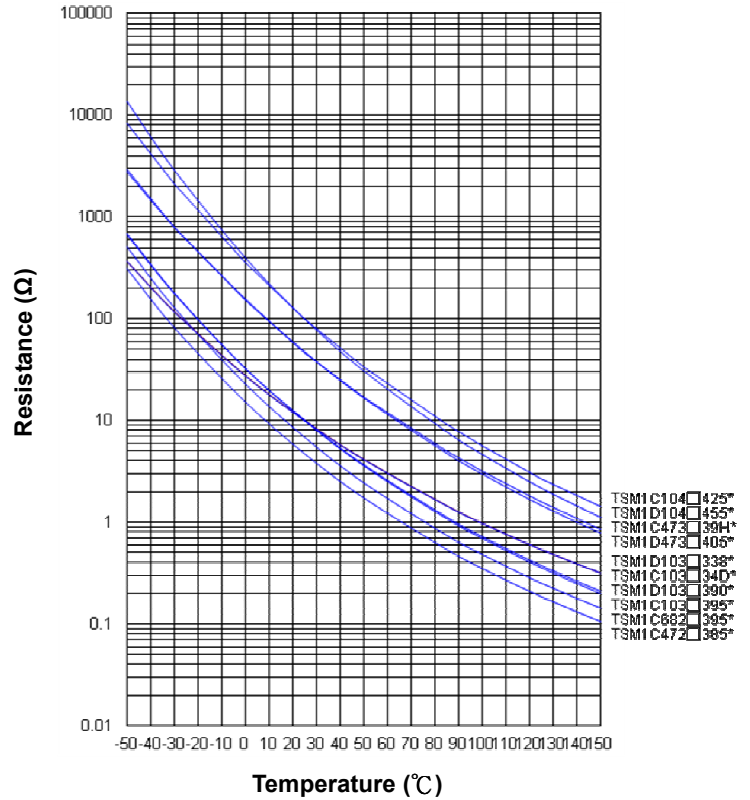

#### 0805 Series

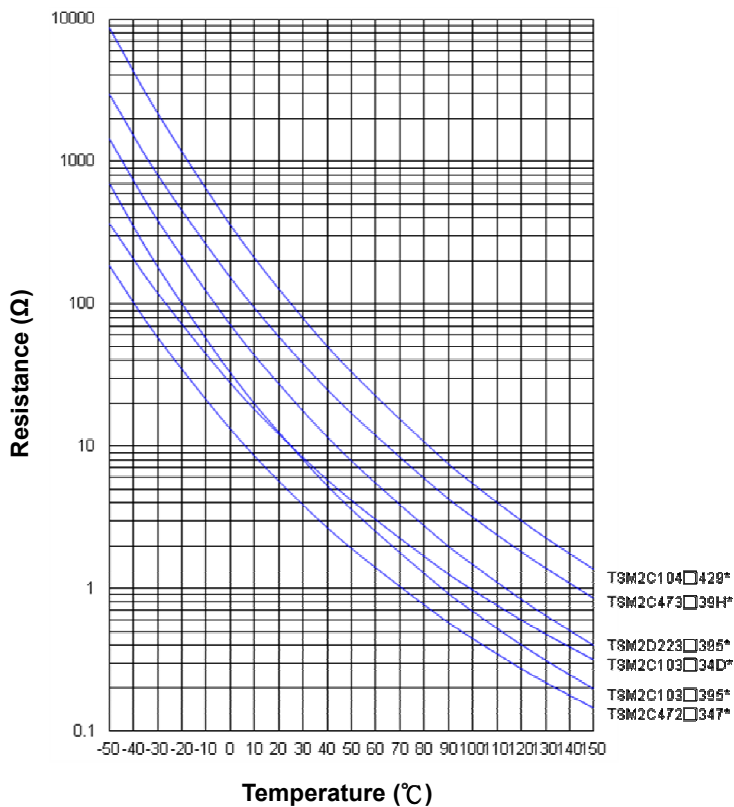

## SMD NTC Thermistor for Temperature Sensing

### ■ Soldering Recommendation

#### ● IR-reflow Soldering Profile

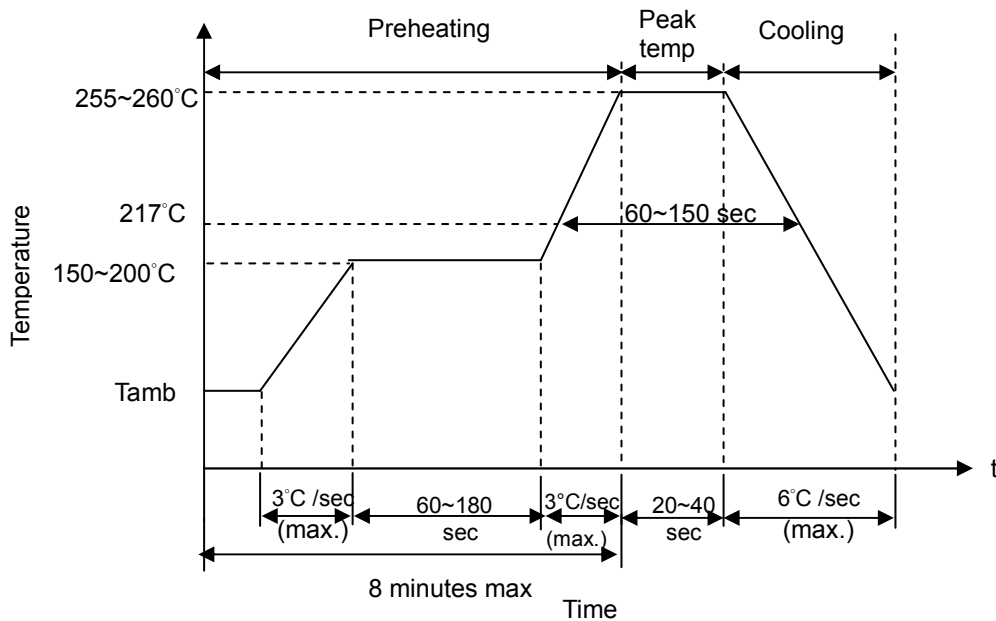

#### ● Reworking Conditions with Soldering Iron

Item	Conditions
Temperature of Soldering Iron-tip	360°C (max.)
Soldering Time	3 sec (max.)
Diameter of Soldering Iron-tip	Φ3mm (max.)

Caution: Do not touch the component surface with soldering iron directly to prevent it from damage.

### ■ Recommended Soldering Pad Dimensions

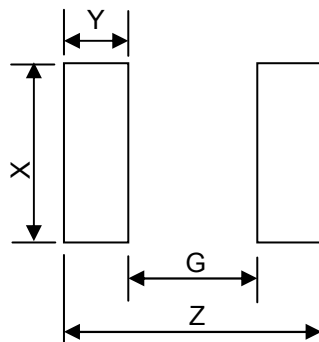

Size (EIA)	Z (mm)	G (mm)	X (mm)	Y (mm)
0402	1.7	0.5	0.6	0.6
0603	2.8	0.8	1.0	1.0
0805	3.4	1.0	1.4	1.2

# NTC Thermistor for Automotive: TSM-C Series

## SMD NTC Thermistor for Temperature Sensing



### ■ Reliability (based on AEC-Q200 Rev-C)

Item	Standard	Test conditions / Methods	Specifications																																										
High Temperature Exposure (Storage)	MIL-STD-202 Method 108	Test temp.: 150 +3/-0°C Duration: 1000 h Unpowered Measurement at 24±2 hours after test conclusion.	No visible damage $ \Delta R_{25}/R_{25}  \leq 5\%$																																										
Temperature Cycling	JESD22 Method JA-104	Lower test temp. : -55 +0/-3°C Upper test temp. : 150 +3/-0°C Soak Time at Lower or Upper Temperature: 1 min Cycle time: 2 Cycles/hr Number of cycles: 1000 Measurement at 24±2 hours after test conclusion.	No visible damage $ \Delta R_{25}/R_{25}  \leq 5\%$																																										
Moisture Resistance	MIL-STD-202 Method 106	Duration of 1 cycle: 24 h Number of cycles: 10, Unpowered Measurement at 24±2 hours after test conclusion.  <table border="1"> <thead> <tr> <th rowspan="2">Step</th> <th colspan="2">Temp. (°C)</th> <th rowspan="2">Humidity (%)</th> <th rowspan="2">Period (hr)</th> </tr> <tr> <th>Start</th> <th>Finish</th> </tr> </thead> <tbody> <tr> <td>1</td> <td>25</td> <td>65</td> <td>90~100</td> <td>2.5</td> </tr> <tr> <td>2</td> <td>65</td> <td>65</td> <td>90~100</td> <td>3</td> </tr> <tr> <td>3</td> <td>65</td> <td>25</td> <td>80~100</td> <td>2.5</td> </tr> <tr> <td>4</td> <td>25</td> <td>65</td> <td>90~100</td> <td>2.5</td> </tr> <tr> <td>5</td> <td>65</td> <td>65</td> <td>90~100</td> <td>3</td> </tr> <tr> <td>6</td> <td>65</td> <td>25</td> <td>80~100</td> <td>2.5</td> </tr> <tr> <td>7</td> <td>25</td> <td>25</td> <td>80~100</td> <td>8</td> </tr> </tbody> </table>	Step	Temp. (°C)		Humidity (%)	Period (hr)	Start	Finish	1	25	65	90~100	2.5	2	65	65	90~100	3	3	65	25	80~100	2.5	4	25	65	90~100	2.5	5	65	65	90~100	3	6	65	25	80~100	2.5	7	25	25	80~100	8	No visible damage $ \Delta R_{25}/R_{25}  \leq 5\%$
Step	Temp. (°C)			Humidity (%)	Period (hr)																																								
	Start	Finish																																											
1	25	65	90~100	2.5																																									
2	65	65	90~100	3																																									
3	65	25	80~100	2.5																																									
4	25	65	90~100	2.5																																									
5	65	65	90~100	3																																									
6	65	25	80~100	2.5																																									
7	25	25	80~100	8																																									
Biased Humidity	MIL-STD-202 Method 103	Test temp. : 85°C Rel. humidity of air: 85% Duration: 1000 h 10% Rated Power. Measurement at 24±2 hours after test conclusion.	No visible damage $ \Delta R_{25}/R_{25}  \leq 5\%$																																										

Item	Standard	Test conditions / Methods	Specifications
Operational Life	MIL-STD-202 Method 108	Test temp. : 150 +3/-0°C Duration: 1000 h Test Power: 1mW Measurement at 24±2 hours after test conclusion.	No visible damage $ \Delta R_{25}/R_{25}  \leq 5\%$
External Visual	MIL-STD-883 Method 2009	Inspect device construction, marking and workmanship.	No visible damage
Physical Dimension	JESD22 Method JB-100	Verify physical dimensions to the applicable device specification.	Within the specified values
Resistance to Solvents	MIL-STD-202 Method 215	Per MIL-STD-202 Method 215 Solvent 1: 1 part (by volume) of isopropyl alcohol 3 part (by volume) of mineral spirits.	No visible damage
Mechanical Shock	MIL-STD -202-213	Test Condition F Peak value: 1500g's Half sine Waveform Normal duration (D) : 0.5ms In 3 directions perpendicularly intersecting each other (total 18 times).	No visible damage $ \Delta R_{25}/R_{25}  \leq 5\%$
Vibration	MIL-STD-202 Method 204	Acceleration: 5 g's Sweep time: 20 min Frequency range: 10 to 2000 Hz 3×12 cycles	No visible damage $ \Delta R_{25}/R_{25}  \leq 5\%$
Resistance to Soldering Heat	MIL-STD-202 Method 210	Condition B No pre-heat of samples. Temperature: 260±5°C, Time: 10±1s Immersion and emersion rate: 25mm/s ±6 mm/s Number of heat cycles: 1	No visible damage $ \Delta R_{25}/R_{25}  \leq 3\%$
Thermal Shock	MIL-STD-202 Method 107	Lower test temp. : -55 +0/-3°C Upper test temp. : 150 +3/-0°C Maximum transfer time: 20 seconds. Dwell time: 15 minutes. Air-Air. Number of cycles: 300	No visible damage $ \Delta R_{25}/R_{25}  \leq 5\%$

# NTC Thermistor for Automotive: TSM-C Series



## SMD NTC Thermistor for Temperature Sensing

Item	Standard	Test conditions / Methods	Specifications
ESD	AEC-Q200 -002	Discharge capacitance: 150 pF Charging voltage: 6 KV Contact discharge 1 pulse in each polarity	No visible damage $ \Delta R_{25}/R_{25}  \leq 5\%$
Solderability	IEC60068-2- 58 J-STD-002	a) 4 h @ 155°C dry heat Dip @245±5°C 3±0.3sec b) Steam aging 8h±15min @93±3°C Dip @260±5°C 7±0.5sec	95% of termination wetted
Electrical Characterization	Specifications	R(-50°C), R(25°C), R(150°C) B(R25°C/R50°C) or B(R25°C/R85°C)	Within the specified values
Board Flex	AEC-Q200 -005 (JIS-C-6429)	Bend the board: 2mm (Min.) Duration: 60 (+5) Sec	No visible damage $ \Delta R_{25}/R_{25}  \leq 5\%$
Terminal Strength	AEC-Q200 -006 (JIS-C-6429)	Apply force: 0402=0.5kg (5 N) 0603=1.0kg (10 N) 0805,1206=1.8kg (17.7 N) Duration of the applied forces: 60 (+1) Sec	No visible damage $ \Delta R_{25}/R_{25}  \leq 5\%$

### ■ Package

#### ● Taping Specification (SMD 0402)

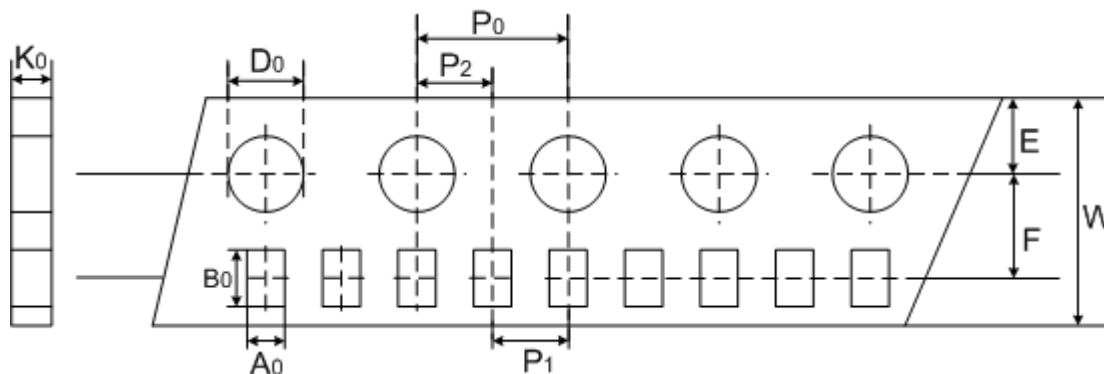

(Unit: mm)

Index Size	$A_0$	$B_0$	$W$	$E$	$F$	$P_1$	$P_2$	$P_0$	$D_0$	$K_0$
0402	±0.05	±0.12	±0.2	±0.1	±0.05	±0.1	±0.05	±0.1	±0.1	±0.1
	0.62	1.12	8	1.75	3.5	2	2	4	1.55	0.60

#### ● Taping Specification (SMD 0603 & 0805)

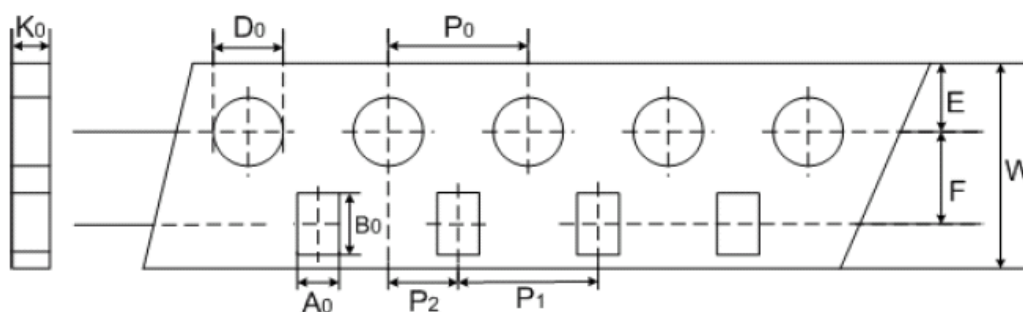

(Unit: mm)

Index Size	$A_0$	$B_0$	$W$	$E$	$F$	$P_1$	$P_2$	$P_0$	$D_0$	$K_0$
0603	±0.2	±0.2	±0.2	±0.1	±0.05	±0.1	±0.05	±0.1	±0.1	±0.1
0805	1.1	1.9	8	1.75	3.5	4	2	4	1.55	0.95
	1.5	2.3	8	1.75	3.5	4	2	4	1.55	1.0



### ■ Quantity

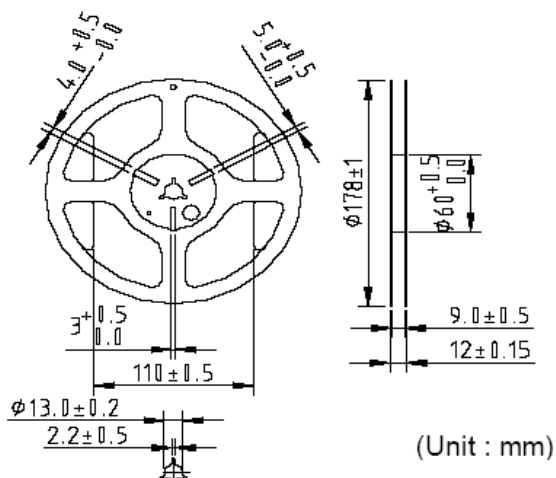

Type	Quantity (pcs/reel)
0402	10,000
0603	4,000
0805	3,500
1206	2,500

### ■ Warehouse Storage Conditions of Products

- Storage Conditions :
  1. Storage Temperature:  $-10^{\circ}\text{C} \sim +40^{\circ}\text{C}$
  2. Relative Humidity:  $\leq 75\% \text{RH}$
  3. Keep away from corrosive atmosphere and sunlight.
- Period of Storage : 1 year